

An introduction to the project

The EnergyWarden consortium- June 2010
<http://www.energywarden.net>



Consortium



CNE TECHNOLOGY Ltd

- » Alexis Onoufriou, MSc/MBA
- » Dr Elias Psimolophitis
- » Dr Panayiotis Philimis



ACCIONA
INFRAESTRUCTURAS SA

- » Sara Prior
- » Jorge Vinuela
- » Manuel Ruiz



APPLIED INDUSTRIAL
TECHNOLOGIES LTD

- » Dr. Sakkas Nikos
- » Maria Kouveletsou



ASM CENTRUM BADAN I
ANALIZ RYNKU SP. Z O O

- » Jagoda Furman (PM)
- » Michal Jablonski



BUILDING RESEARCH ESTABLISHMENT

- » Dr Stephen Garvin
- » David Shearer



D'APPOLONIA SA

- » Dr. Thomas B. Messervey
- » Daniela Reccardo



DAEDALUS INFORMATICS LTD

- » E. M. Mylonas
- » Costas Vouros
- » Takis Bouyouiris



FUNDACION FATRONIK

- » » Zigor Lizuain
- » Alberto Carrascal



MIHAJLO PUPIN

- » Dr. Sanja Vranes
- » Dr. Mladen Stanojevic
- » Dr. Zeljko V. Despotovic
- » Aleksandar Vitorovic
- » Marko Batic

EnergyWarden has been financially supported
by the European Commission, DG INF50,
under the 7th Framework Programme



Objectives and Products

- Decision support to **optimal deployment of renewable energy technology (RET) to buildings**
 - **EWS- standalone version (web application)**
- Development of a controller to carry out **monitoring and supervisory control of energy sourcing**
 - **EWS/EWC- integrated version (firmware)**
- Assessment of **energy module performance** and provision of building real time indicators (CO2 savings, etc.)
 - **EWU- add on module (web application)**



EW graphical illustration

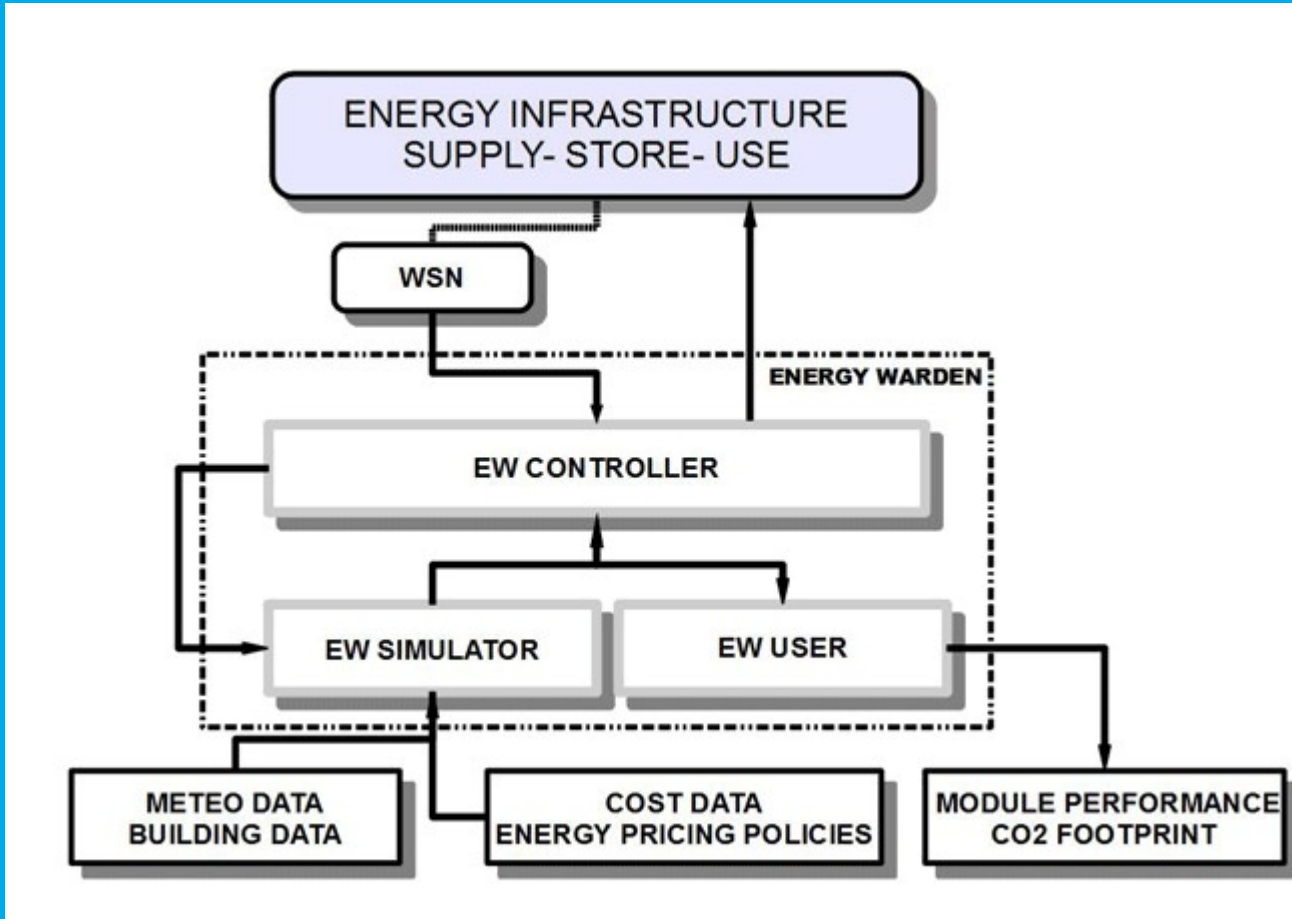

Milestones

Task	Month
EWS On-line	16
EWC Demo 1	28
EWC Demo 2	32
EWU Integration	34



EWS; status

- **RET modelling**
 - Device dynamic model development
 - Configuration modelling
 - Energy use modelling
- **Data modelling**
- **Application design**



EWS; modelling context

- **Energy sourcing**

- Solar/ thermal
- Solar/ PV
- Wind
- Geothermal
- Multiple electricity suppliers
- Locally produced electric energy

- **Energy store**

- Batteries
- Hot Water
- Hydrogen/fuel cell
- Phase changing materials

- **Energy use**

- local electricity loads
- use Water heating
- space Heating/Cooling

- selling to the grid and district



EWS; data (examples)

- Building profile
 - Meteorological data
 - Energy use profile (configurations of energy use hourly/daily/weekly/yearly)
- Building renewable energy value
- Energy pricing
- User preferences
- RET configurations
- RET device and installation data
- RET providers
- Financial context



EWS; applications (examples)

- User management
- Project management
- Building definition
- RET configuration selection
- RET configuration validation
- RET sizing
- Hourly/Daily/Monthly/Yearly simulation based on input data
- Financial appraisal
- RET provider selection



GR demo- general overview

- ❑ Energy production
 - Pv panels
 - Wind turbine
 - Solar thermal
- ❑ Energy store
 - Battery
- ❑ Energy use
 - Space heating
 - Hot water use
 - Lighting
 - Grid

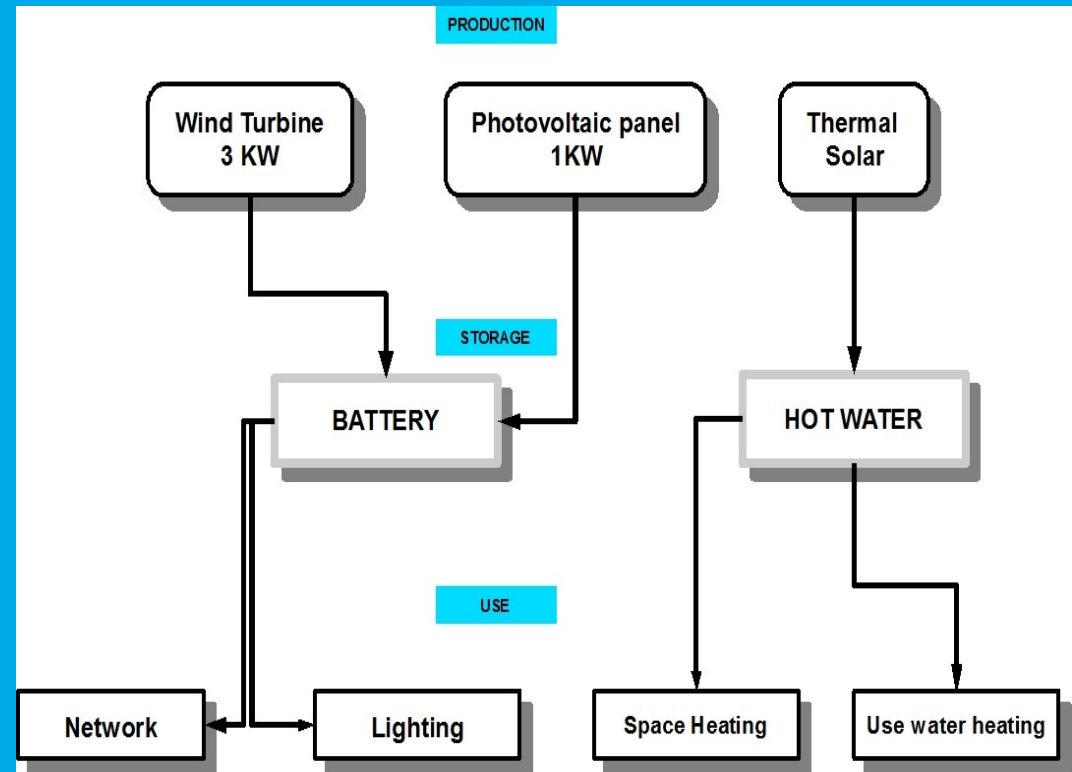

GR demo- WSN overview

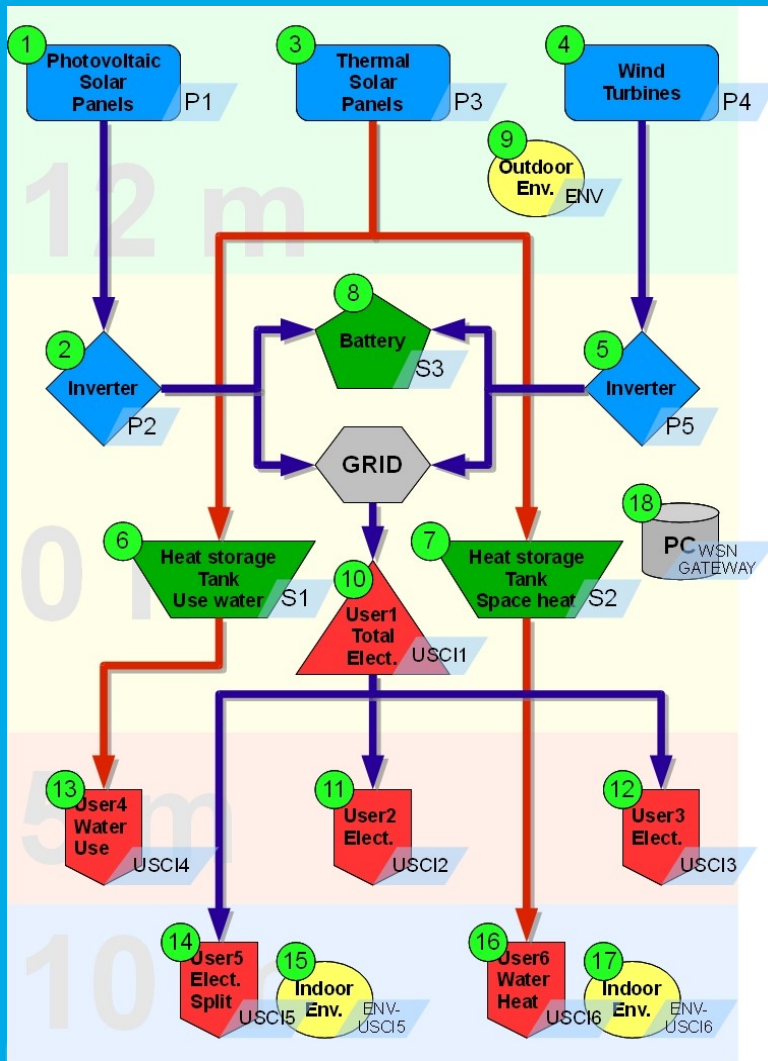

- 17 sensing points
 - 5 production sensing points
 - 3 storage sensing points
 - 1 outdoor environmental point
 - 6 user selected consumption items
 - 2 indoor environmental points

- 1 WSN Gateway- PC

EWC; functionality

- Building **monitoring**
 - Energy (production, store, consumption)
 - Device performance
- Energy **sourcing, supervisory control**
- **EWS tuning** based on real time data
- **EWU data provider**



EWC; Supervisory control

Management of Electricity & Thermal Energy produced from RETs

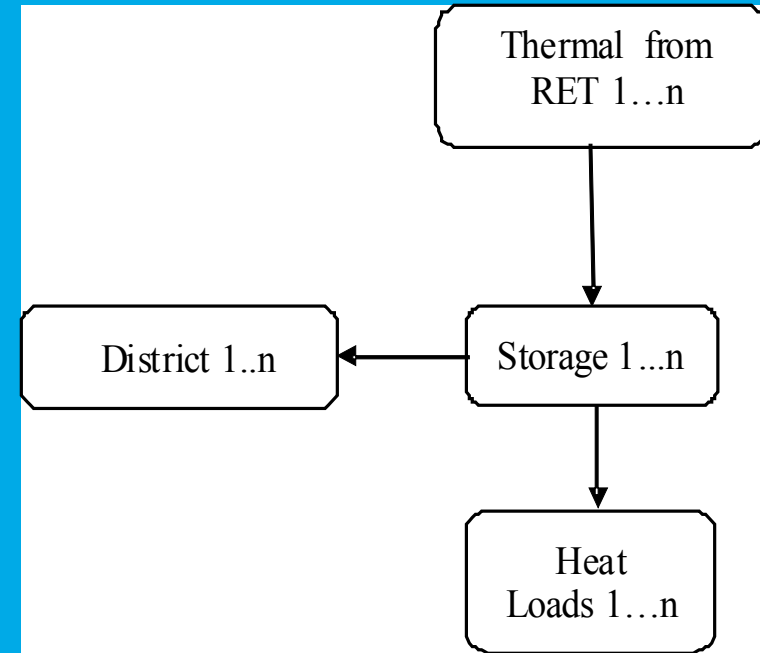
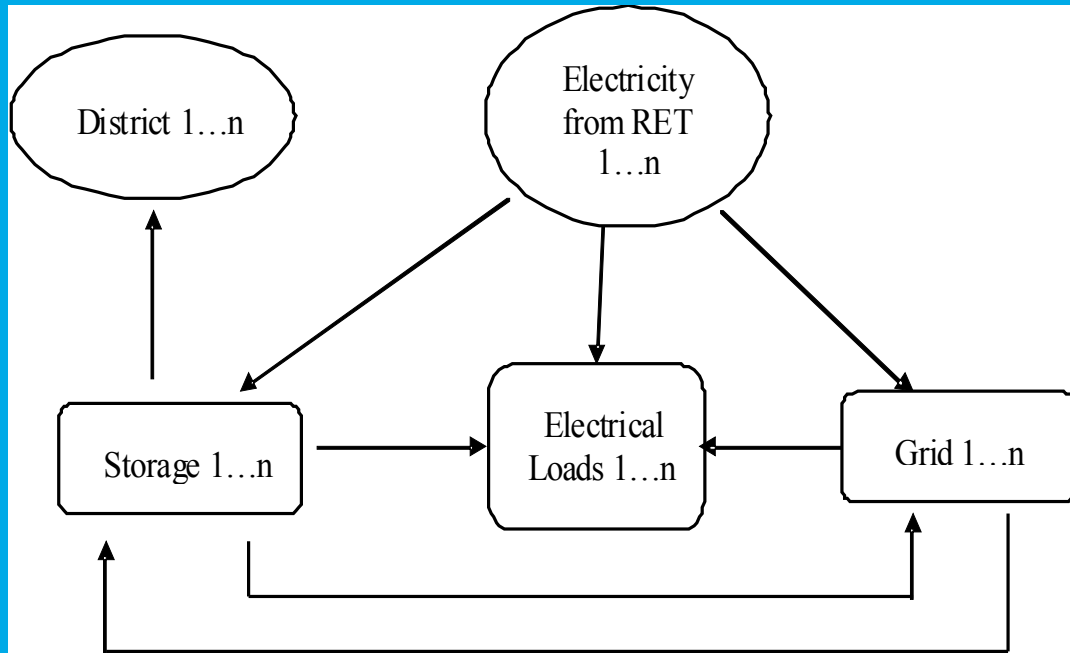

EWC protocols

- EWC will be designed to be compliant with:
 - **802.14.5** base solution (EWC.802)
 - **BMS protocol** based solution (EWC.BMS)



EWC.802- H/W aspects

- **Wireless base station** including M/C for field data collection.
- **Specialised EWC-M/C** to:
 - Carry out supervisory control
 - Configure the EWC
- **Memory** to store:
 - 1: 802.15.4 incoming field data
 - 2: EWC configuration data
 - 3: EWS set-points
- **Digital outputs for supervisory control**; enable/disable signals
- **USB/serial to connect to PC** and transfer data/receive set-points
- **TCP/IP** to connect directly to LAN



EWC.802- software aspects

- **Programmatic access to the base station M/C to:**
 - Configure the WSN
 - Collect the data and store in Memory-1
 - Transfer from Memory-1 to EWC-Database
- **Programmatic access to EWC-M/C to:**
 - Configure the EWC and store in Memory-2
 - Receive the EWS setpoints and store in Memory-2
 - Read Memory-1-2-3 data and carry out control
- **Transfer data to web or local connectivity to PC over USB/serial**



EWU – User Module

- **Monitoring in real time the performance of producing and storage devices** using
 - Sensor data
 - Calculations based on EN and ISO standards of producing and storage devices
- **Calculating in real-time user preferences** e.g. income, ROI etc.
- **Calculating in real-time CO₂ savings** for emissions trading schemes
- **Support policy (directives etc.)** and subsidy schemes
 - Promotion of electricity produced from renewable energy sources
 - Support subsidy schemes with network connection for verification (Guarantee of Origin of electricity produced from RES)



EW Newsletter

- **Addendum to existing construction Newsletter** with substantial distribution base
- Focus on **building energy management issues**
- Opportunity for **dissemination of project information** (with emphasised the commercial aspects)
- **Free registration** at

http://www.building-21.net/nl_sub.html



The screenshot displays the RegCon.gr website interface. At the top left, the RegCon.gr logo is accompanied by the text "Clustering and Innovation in Construction" and its Greek equivalent "Συνοργάνωση και Καινοτομία στις Κατοικίες". A navigation menu is visible in the top right corner. The main content area is titled "Newsletter. Issue No.2, 2/2010" and includes a link for the "Greek version available". Below this, a "Contents" section lists items such as "RegCon.gr. New product- service presentation", "Interview from the industry", and "News from the world". A registration prompt asks if the user wants to receive new issues in their mailbox. The right sidebar features an "Interview with Mrs. Mariotis, Mng. Director of RealtyCrete" with the RealtyCrete logo. The footer contains information about "RegCon.gr products and services" and a "NEW SERVICE" section.



Thank you!

Presenters:

Nikos **Sakkas**, Dr. Eng

APINTECH, www.apintech.com

Panayiotis **Philimis**, Dr. Eng

CNE TECHNOLOGY, www.cnetechtechnology.com

